



Three branches of phospholipase C signaling pathway promote hepatocyte growth in rat liver regeneration

G.G. Xu^{1,2}, Z. Geng^{1,2}, X.C. Zhou^{1,2}, Y.G. He^{1,2}, T.T. He^{1,2}, J.X. Mei^{1,2}, Y.J. Yang^{1,2}, Y.Q. Liu^{1,2} and C.S. Xu^{1,2}

¹College of Life Science, Henan Normal University, Xinxiang, China

²Key Laboratory for Cell Differentiation Regulation, Xinxiang, China

Corresponding author: C.S. Xu

E-mail: cellkeylab@126.com

Genet. Mol. Res. 14 (2): 5710-5723 (2015)

Received February 25, 2014

Accepted September 22, 2014

Published May 29, 2015

DOI <http://dx.doi.org/10.4238/2015.May.29.3>

ABSTRACT. In general, the phospholipase C (PLC) signaling pathway is involved in many physiological activities, including cell growth. However, little is known regarding how the PLC signaling pathway participates in regulating hepatocyte (HC) growth during liver regeneration (LR). To further explore the influence of the PLC signaling pathway on HCs at the cellular level, HCs of high purity and vitality were isolated using Percoll density-gradient centrifugation after partial hepatectomy. The genes of the PLC signaling pathway and target genes of transcription factors in the pathway were obtained by searching the pathways and transcription factor databases, and changes in gene expression of isolated HCs were examined using the Rat Genome 230 2.0 Microarray. The results suggested that various genes involved in the pathway (including 151 known genes and 39 homologous genes) and cell growth (including 262 known genes and 37 homologous genes) were associated with LR. Subsequently, the synergetic effect of these genes in LR was analyzed using a mathematical model (E_i) according to their expression profiles. The results showed that the E_i values of G protein-

coupled receptor/PLC, integrin/PLC, and growth factor receptor/PLC branches of the PLC pathway were all significantly strengthened during the progression and termination phases of LR. The synergetic effect of target genes, in parallel with target gene-related cell growth, was also enhanced during whole rat LR, suggesting the potential positive effect of PLC on HC growth. The present data indicate that the PLC signaling pathway may promote HC growth through 3 mechanisms during rat LR after partial hepatectomy.

Key words: Gene expression profile; Gene synergistic effect; Hepatocyte growth; Phospholipase C signaling pathway; Rat liver regeneration

INTRODUCTION

The liver is a crucial organ with very high regeneration ability (Fausto et al., 1995). It is comprised of hepatocytes (HCs), bile duct epithelial cells, and various other types of cells. HCs are the major hepatic cell type, accounting for 70-80% of hepatic mass and 65% of total hepatic cells (Sell, 2003); these cells have many physiological functions, including storage, metabolism, bile secretion, oxidation protection, detoxification, and production of many growth factors and cytokines (Fausto et al., 1995). A large number of quiescent HCs can synchronously re-enter the cell cycle and proliferate to compensate for lost liver tissues after liver injury or partial hepatectomy (PH). This process is known as liver regeneration (LR). The regeneration process is divided into 3 stages according to cellular physiological activities: initiation (2-6 h after PH), progression (6-72 h after PH), and termination (72-168 h after PH) (Fausto, 2004; Taub, 2004; Xu et al., 2007). It is well-known that the process involves various physiological and biochemical activities such as cell activation, cell growth and proliferation, re-differentiation, and structure and function rebuilding (Steer, 1995; Kountouras et al., 2001), and is regulated by various signaling pathways (Brenner, 1998; Sun et al., 2007).

It is generally acknowledged that the phospholipase C (PLC) signaling pathway is a complex signaling transduction network composed of many branches. Several extracellular signaling molecules in combination with their receptors activate PLC in the PLC pathway, which hydrolyzes phosphatidylinositol-4,5-bisphosphate into 2 secondary messengers, inositol-1,4,5-trisphosphate (IP_3) and diacylglycerol (DAG). IP_3 triggers the release of calcium from intracellular stores, while DAG mediates the activation of protein kinase C (PKC), which directly regulates a variety of cellular functions, including cell growth (Moolenaar et al., 1984; Cockcroft and Thomas, 1992; Cerbon et al., 2009). PLC, a very important phosphoinositide-specific and key enzyme in cellular signaling, is categorized into 6 classes, including the β (1-4), γ (1, 2), δ (1, 3, 4), ϵ , ξ , and η (1, 2) types (Fukami et al., 2010). The PLC pathway can be activated by different receptors (Kawakami and Xiao, 2013), and is thus classified into 3 branches, including G protein-coupled receptor (GPCR)/PLC, growth factor receptor (GFR)/PLC, and integrin/PLC. Among these, the GPCR/PLC branch activates PLC through GPCR→G proteins ($G\alpha$, $G\beta$, $G\gamma$)→AC→cAMP→EPAC→Rap or RhoGEF→Rho/Rac. The GFR/PLC branch activates PLC through growth factors→growth factor receptors→SHC, GRB2, SOS→Ras→RalGDS→Ral, and the integrin/PLC branch activates PLC through extracellular matrix proteins→integrin→c-Src. After PLC is activated by GPCR, GFR, and in-

tegrin through the 3 branches, phosphatidylinositol-4,5-bisphosphate is hydrolyzed. Next, the Ca^{2+} -dependent proteins calmodulin/calcineurin are activated through the IP_3 - Ca^{2+} pathway, while $\text{Raf1} \rightarrow \text{MEK1/2} \rightarrow \text{ERK1/2}$ and nuclear factor (NF)- κB are activated through the DAG-PKC pathway. After the double-messenger system transmits the signals from the cell surface into the nucleus, transcription factors, including nuclear factor of activated T-cells (NFAT) (Caetano et al., 2002; Graef et al., 2003), cAMP response element-binding (CREB) protein (Mantamadiotis et al., 2012), C-JUN/C-FOS, NF- κB (Moore-Carrasco et al., 2009), and C-MYC are activated to promote cell growth.

In general, numerous genes are involved in PLC signaling pathways and cell growth and involve complex interactions among genes. Thus, systems biology methods must be applied to analyze the regulatory networks and sequences of PLC signaling pathways in modulating HC growth. Moreover, the PLC signaling pathway includes the above 3 branches. However, little is known regarding which branches regulate cell growth of HCs during LR. Therefore, in the present study, we examined the effect of PLC on rat LR at the cellular level by determining the expression profiles of genes related to the PLC signaling pathway in HC regeneration at 10 time points after PH using the Rat Genome 230 2.0 Microarray, their synergistic effects were assessed using a mathematical model (*E_i*). These data not only reveal information regarding the mechanism of LR, but also provide target selections for the clinical treatment of liver-related diseases.

MATERIAL AND METHODS

Preparation of the rat PH model

Adult male Sprague-Dawley rats (12 weeks old), each weighing 230 ± 20 g, were obtained from the animal center of Henan Normal University. A total of 114 rats were randomly divided into 9 groups for 2/3 hepatectomy (PH), 9 for sham operation (SO), and a control group including 6 rats per group. Rats in the PH groups were subjected to PH following the method of Higgins and Anderson (1931). Briefly, the left and median lateral liver lobes were surgically removed, and the rats in SO groups underwent the same operation process without liver lobe removal. Rats were sacrificed at 0, 2, 6, 12, 24, 30, 36, 72, 120, and 168 h after PH. The Animal Protection Law of China was followed in this study.

Isolation and identification of hepatocytes from the regenerating rat liver

Rats were anesthetized with ether and sterilized with 75% ethanol (analytically pure, AR) before opening the abdominal cavity. The vena cava below and above the liver were ligated following catheterization of the liver portal vein. HCs were isolated using conventional 2-step perfusion and Percoll density-gradient centrifugation according to the method previously described by Xu et al. (2012). Finally, the HC marker proteins albumin (ALB) and glucose-6-phosphatase (G6PC) were used to identify HCs by immunocytochemistry (Xu et al., 2012). Briefly, purified HCs were fixed with 10% formaldehyde for 30 min and then smeared onto polylysine-coated glass slides. After the cell suspension dried, a peroxidase block step was performed. Next, the sections were incubated separately with a 1:200 dilution (v/v) of ALB and G6PC antibodies at 4°C overnight. A 1:5000 (v/v) diluted biotin-labeled secondary antibody was added at 37°C for 1 h. The system was hybridized with a streptavidin-biotin

complex at 37°C for 30 min. HC viability was measured by trypan blue staining. Purity and viability of the HCs used in this study were greater than 95%.

RNA extraction and Rat Genome 230 2.0 Microarray detection

Total RNA was extracted, purified, and detected using the Rat Genome 230 2.0 Microarray following previously described protocols (Xu et al., 2010). Briefly, total RNA from 1×10^6 HCs was extracted with Trizol reagent following manufacturer instructions (Invitrogen, Carlsbad, CA, USA) and purified following the RNeasy mini protocol (Qiagen, Hilden, Germany). Biotin-labeled cRNA was obtained using the GeneChip *In Vitro* Transcript Labeling Kit (ENZO Biochemical, Farmingdale, NY, USA), and then digested into 35-200-bp cRNA fragments. The prehybridized Rat Genome 230 2.0 Microarray was added to hybridization buffer, and the hybridization reaction was conducted at 45°C in a hybridization oven (Affymetrix, Santa Clara, CA, USA) at 60 rpm for 16 h. The hybridized arrays were washed and stained in a GeneChip® Fluidics Station 450 (Affymetrix), then scanned and imaged using a GeneChip scanner 3000 (Affymetrix). Images reflecting gene expression abundance were converted into normalized signal values, and P values, log ratios, and change in P values at each time point were calculated and compared to the normal control group (0 h) using the Affymetrix GCOS 2.0 software. To minimize technical errors from the microarray experiments, isolated HCs from control groups and PH groups were detected using the Rat Genome 230 2.0 Microarray at least 3 times (Amon et al., 2003; Nikitin et al., 2003; Mulrane et al., 2008).

Quantitative real-time polymerase chain reaction (qRT-PCR)

Total RNA was extracted and purified following previously described protocols (Wang and Xu, 2010). Briefly, primers for β -actin, HGF, JUN, FOS, and MYC were designed using the Primer Express 5.0 software. The first chain of cDNA was synthesized using the SuperScript II RT reverse transcription system. PCRs were performed using the conditions for SYBR Green I: 2 min at 95°C, followed by 40 cycles for 15 s at 95°C, 15 s at 60°C, and 30 s at 72°C. Each sample was amplified in triplicate. Next, PCR products were subjected to melting curve analysis to confirm the specificity of amplification. The housekeeping β -actin gene was used as an internal control.

Identification of PLC signaling pathway- and cell growth-related genes in HCs

First, the terms “PLC signaling pathway” and “cell growth” were input into NCBI (www.ncbi.nlm.nih.gov) and RGD (rgd.mcw.edu) to identify rat, mouse, and human genes associated with the PLC signaling pathway or cell growth. The genes were collated and collected according to physiological pathway maps in the Ingenuity Pathway Analysis 9.0 (IPA) software, GENMAPP (www.genmapp.org), KEGG (www.genome.jp/kegg/pathway.html), and QIAGEN (www.qiagen.com/geneglobe/pathways.aspx) (Salomonis et al., 2007; Antonov et al., 2010). Moreover, PLC signaling pathway-regulated transcription factors (TFs) such as CREB, NFAT, NF- κ B, C-JUN, C-FOS, and C-MYC were input into TRED (<http://rulai.cshl.edu/cgi-bin/TRED/tred.cgi?process=searchTFGeneForm>) and Lymph TF DB (<http://www.iupui.edu/~tfinterx/activity.php>) to identify their downstream target genes in rat (Childress et al., 2007; Jiang et al., 2007), mouse, and human; cell growth-related

genes among these downstream targets were identified in the NCBI database. The genes were reconfirmed through literature searches of pertinent articles. The BLAST program was used to identify homologous LR-related genes (Sankian et al., 2005), and unknown gene homologous to PLC signaling pathway- and/or cell growth-related genes were considered to possess the same function.

Confirmation of significantly changed genes and LR-related genes during rat LR

The normalized log ratio values of PH compared to controls were used to calculate the relative value of each gene (ratio values), and ratio values of ≥ 3 , ≤ 0.33 , and 0.33-2.99 indicated that gene expression was significantly up-regulated, significantly down-regulated, and biologically insignificant, respectively, during LR (Vardhanabhuti et al., 2006). In addition, the *F*-test was used to analyze the significance of gene expression differences between the PH and SO groups (de Menezes et al., 2004). Genes that were changed for at least at 1 time point during LR with a significant difference ($0.01 \leq P < 0.05$) or extremely significant difference ($P \leq 0.01$) between the PH and SO groups were considered to be associated with LR.

Synergy analysis of genes related to the PLC signaling pathway and cell growth

A mathematical model (E_t) was established by Xu et al. (2012) and used to describe how physiological activities are governed by gene synergy according to the expression level of genes detected using the Rat Genome 230 2.0 Microarray. Based on multivariate statistical methods and time series analysis methods, and the assumption that physical activity is regulated by the synergy of various genes, the spectrum function $E(t)$ was described as follows:

$$E(t) = \frac{\sum_{i=1}^{n-1} \sum_{k=i+1}^n [(X_i(t) + X_k(t)) \cdot |r_{ik}|]}{C_n^2} = \frac{\sum_{i=1}^{n-1} \sum_{k=i+1}^n [(X_i(t) + X_k(t)) \cdot |r_{ik}|]}{\frac{n(n-1)}{2}} \quad (\text{Equation 1})$$

In the formula, the genes' correlation coefficient (r_{ik}) is defined by the Pearson correlation coefficient:

$$r_{ik} = \frac{n \left(\sum_{t=1}^n X_i(t) X_k(t) \right) - \left(\sum_{t=1}^n X_i(t) \right) \left(\sum_{t=1}^n X_k(t) \right)}{\sqrt{\left[\sum_{t=1}^n X_i^2(t) - \left(\sum_{t=1}^n X_i(t) \right)^2 \right] \left[\sum_{t=1}^n X_k^2(t) - \left(\sum_{t=1}^n X_k(t) \right)^2 \right]}} \quad (\text{Equation 2})$$

Here, n is the number of all genes participating in a physiological activity at t time point. The spectral function $E(t)$ describes the effectiveness of gene synergy dominating a physiological activity at a given time point. Comparison with the control predicted the strength of the physiological activities. At t time point, assuming that the reference value is $E(0)$, the corresponding physical activity is increased compared to the control when $E(t) - E(0) \geq E(0)$, is decreased when $E(t) - E(0) < 0$, and is similar to the control when $E(0) < E(t) < 2E(0)$.

RESULTS

Isolation and identification of HCs

In this study, we demonstrated the purity and activity of HCs isolated from liver samples. The results showed that the positive regions of ALB and G6PC were distributed throughout the cytoplasm of HCs. HC activity was greater than 95%. In addition, the percentages of the ALB- and G6PC-positive cells among isolated cells were greater than 95% at any recovery time point after PH (Figure 1).

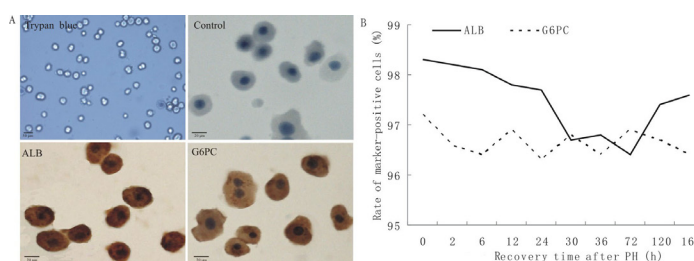

Figure 1. ALB, G6PC immunostaining, and trypan blue exclusion test of HCs isolated from the rat liver. **A.** “Control” was a negative control incubated with phosphate-buffered saline instead of anti-ALB or anti-G6PC antibody. HCs were stained with 0.4% trypan blue. **B.** Percentage of positive HCs at 10 time points (h) after PH in rats.

Validation of Rat Genome 230 2.0 Microarray results

To validate the results of Rat Genome 230 2.0 Microarray analysis, 4 randomly selected genes were subjected to qRT-PCR. The results showed that the expression trends detected by the 2 methods were generally consistent, suggesting that the microarray results were reliable. The results of *HGF*, *JUN*, *FOS*, and *MYC* are shown in Figure 2.

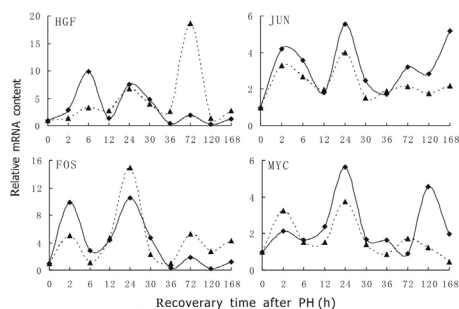

Figure 2. Comparison of relative mRNA levels in regenerating HCs detected using the Rat Genome 230 2.0 Microarray (dotted lines) and qRT-PCR (solid lines) during LR.

Expression changes of the PLC signaling pathway during rat LR

The results of database searching and biological pathway maps revealed 3 branches, GPCR/PLC, integrin/PLC, and GFR/PLC, including 411 genes involved in the PLC signaling pathway, among which 356 were known genes and 39 were unknown homologous genes in the Rat Genome 230 2.0 Microarray. Comparison analysis of the PH and SO groups using

the *F*-test indicated that 190 genes were significantly changed in HCs in the regenerating liver, which may be rat LR-related genes. Of these, 135 known genes and 35 unknown homologous genes were up-regulated, while 12 genes and 3 unknown homologous genes were down-regulated. Five genes, including *CLEC14A*, *KDR*, *FBNI*, *LAMB2*, and *BI274487*, were up/down-regulated (Figure 3 and [Table S1](#)).

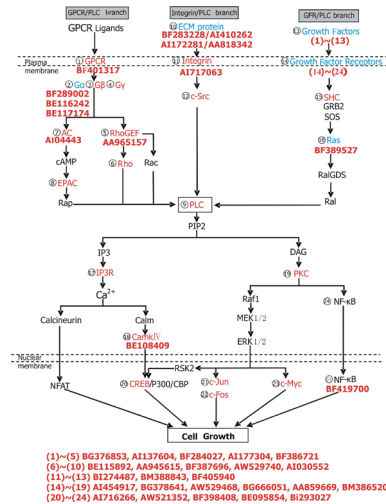

Figure 3. Pathways of the PLC signaling pathway and their inter-relationships. The symbols in red represent meaningful up-regulated genes, blue denotes up/down-regulated genes, and black are insignificantly changed genes. The symbols in red bold indicate the genes homologous to the upper gene. The symbols in black bold show the activity studied in this study. The numbers in circles are consistent with the numbers of proteins shown in [Table S1](#).

Expression changes of HC growth-related genes and those regulated by PLC signaling during rat LR

Similarly, the data from NCBI and RGD, as well as the biological pathway maps (e.g., KEGG, QIAGEN) showed that 727 genes were involved in cell growth, among which 674 known genes and 37 unknown homologous genes were included in the Rat Genome 230 2.0 Microarray. Comparison analysis of the PH and SO groups using the *F*-test indicated that expression of 299 genes was significantly altered in HCs in the regenerating liver and could be considered LR-related genes. Of these, 225 genes, including *ABCBI* and 31 unknown homologous genes were up-regulated, 34 genes, such as *ABTB2* and 6 unknown homologous genes, were down-regulated, and 3 genes, including *CISH*, *KDR*, and *PTPRB*, were up/down-regulated ([Table S2](#)).

Data from TRED and Lymph TF DB showed that among the target genes regulated by these TFs (e.g., *NFAT*, *CREB*, *C-JUN/C-FOS*, *NF-κB*, and *C-MYC*) in the PLC pathway, 1273 genes were present in the Rat Genome 230 2.0 Microarray, and 154 known genes and 12 unknown homologous genes were cell growth-related genes. Difference analysis of gene expression in the PH and SO groups indicated that the expression of 83 genes was significantly altered in HCs of the regenerating liver and were considered LR-related genes, among which 62 known genes, including *ABCBI* and 9 unknown homologous genes, were up-regulated, 8 known genes, including *ADRA1B* and 3 unknown homologous genes, were down-regulated, and *KDR* was up/down-regulated (Table 1).

Table 1. Expression changes of HC growth-related genes regulated by the PLC signaling pathway during rat liver regeneration.

Gene	Associate to transcription factors	Recovery time (h) after partial hepatectomy									
		0	2	6	12	24	30	36	72	120	168
ABCBI	2,4	1.00	1.53	0.49	1.67	4.50	4.05	4.16	1.56	1.23	0.99
ACE	2	1.00	3.21	3.22	2.57	3.71	3.83	3.14	4.74	3.42	4.39
AW530948	2	1.00	0.72	0.51	0.41	0.24	0.49	0.41	0.41	0.29	0.45
ADRA1A	1	1.00	1.31	1.67	0.93	2.08	3.14	1.61	0.92	1.10	1.85
ADRA1B	1	1.00	0.56	0.26	0.16	0.74	0.45	0.62	0.85	0.95	1.26
ADRA1D	1	1.00	3.31	1.10	0.87	0.74	1.44	1.96	0.80	1.85	2.20
AGT	4	1.00	1.97	3.02	2.39	1.37	1.38	1.07	1.22	1.05	1.11
AGTR2	2	1.00	1.67	2.57	1.30	2.23	3.08	2.55	1.28	1.41	1.70
AHRR	4	1.00	3.49	12.60	8.46	22.44	4.70	12.20	21.74	5.62	1.41
BARD1	5	1.00	1.47	1.29	1.02	24.44	26.20	16.87	1.81	1.09	1.04
AI072122	5	1.00	1.47	0.88	0.67	10.05	7.22	10.13	3.43	2.69	0.49
BCAT1	5	1.00	2.48	1.25	1.77	2.61	2.45	2.56	1.85	3.12	2.99
BCL2	1,3,4	1.00	3.07	1.85	4.39	3.60	5.06	4.98	6.04	3.06	3.15
BF398185	1,3,4	1.00	13.63	22.68	2.63	17.98	16.62	30.78	2.94	22.32	13.56
BE109363	1,3,4	1.00	1.72	1.79	3.19	2.66	2.07	2.98	3.30	3.46	3.58
BST1	1,4	1.00	2.67	5.00	1.26	6.47	13.26	6.60	15.79	6.60	1.43
CCL2	2,4	1.00	5.95	6.20	2.52	8.15	16.12	15.93	21.05	6.33	1.49
CD44	2,4	1.00	2.11	2.81	4.45	2.99	4.20	3.41	4.89	3.15	2.20
BI302830	2,4	1.00	1.53	1.00	3.84	2.89	4.93	4.80	5.27	1.67	2.59
CDKN1A	1,2,4	1.00	3.40	2.62	1.58	1.76	2.96	1.53	0.70	1.18	1.04
CSRP3	3	1.00	1.25	3.10	2.28	2.02	6.77	1.91	1.39	1.05	3.23
CYR61	1	1.00	1.15	1.44	1.52	9.95	4.03	6.26	5.40	2.50	1.69
EMP1	5	1.00	1.12	2.84	2.17	1.81	2.97	2.68	3.79	2.30	2.56
ESR1	2	1.00	7.26	2.20	2.52	2.72	2.45	2.10	1.63	2.95	1.54
AI407487	2	1.00	1.22	0.76	0.31	0.72	0.36	0.46	0.50	0.48	1.07
FGF8	4	1.00	1.13	2.89	1.41	1.33	4.40	1.53	1.60	1.56	2.84
FGFR1	2	1.00	0.67	2.55	0.92	3.74	2.29	2.35	6.36	4.81	2.36
FOXM1	5	1.00	1.41	1.19	0.40	6.73	5.86	5.82	1.85	1.11	0.65
FYN	4	1.00	0.61	2.53	1.47	2.95	2.63	3.16	9.87	4.19	3.27
GADD45B	4	1.00	148.86	34.04	17.96	21.46	29.10	10.87	42.88	25.52	11.86
HGF	1,4	1.00	1.37	3.23	2.73	6.76	3.91	2.54	18.65	1.43	2.77
IFNG	1,3,4	1.00	1.21	0.74	0.31	0.87	1.06	0.92	0.78	0.50	0.92
IGF1	2	1.00	1.11	1.15	0.95	0.99	0.69	0.71	1.09	1.13	1.22
AA945615	2	1.00	1.13	1.05	0.69	0.79	0.22	0.46	0.60	0.94	0.84
IGFBP1	1,4	1.00	4.77	1.04	1.59	2.38	1.52	1.15	2.41	1.89	1.85
IGFBP2	2,4	1.00	2.77	0.70	1.62	0.23	0.47	0.78	0.68	1.12	1.02
IL5	2,4	1.00	1.19	1.33	0.48	1.29	0.69	0.32	0.96	1.29	0.79
IL6	1,2,4	1.00	2.34	1.75	2.15	2.40	2.92	1.04	2.28	2.27	1.14
BF387696	1,2,4	1.00	2.78	2.44	2.00	4.92	2.58	2.97	4.67	1.33	4.64
KDR	4	1.00	0.22	0.33	0.12	1.18	0.77	1.16	5.35	2.33	1.57
LEF1	4	1.00	1.14	1.43	1.40	1.12	1.64	1.23	1.79	1.16	1.38
AA998997	4	1.00	2.50	4.04	2.69	2.68	4.11	4.93	4.84	3.57	4.18
MCAM	1	1.00	2.50	1.62	2.26	3.44	2.63	3.63	7.04	2.33	2.51
MET	1,2,4,5	1.00	1.43	0.36	0.58	0.64	0.75	0.51	0.23	0.36	0.70
MINA	5	1.00	1.50	2.02	2.44	3.40	2.75	3.00	5.48	2.46	1.95
MMP9	2,4	1.00	1.58	1.52	1.89	5.62	1.75	1.89	3.22	2.89	0.85
NCL	2,5	1.00	1.32	2.15	3.17	1.68	1.64	1.79	0.99	1.05	1.04
NDRG1	5	1.00	1.59	2.55	3.55	3.33	1.92	0.95	3.71	1.81	2.03
NFI	1	1.00	4.33	4.50	4.93	1.90	3.65	3.95	3.57	4.86	3.82
AW917689	1	1.00	1.80	2.76	1.75	3.85	3.63	3.53	2.05	2.70	1.88
NGF	4	1.00	4.81	1.11	2.62	0.99	1.26	2.17	2.38	3.42	4.68
NPM1	5	1.00	1.36	1.62	3.79	1.41	2.09	1.38	0.67	0.89	1.04
NPPA	1,2	1.00	1.84	0.54	1.45	1.29	2.81	1.68	1.48	2.10	3.03
NPRI	1	1.00	0.49	1.38	2.74	2.60	2.26	5.04	11.68	3.64	2.51
NRG1	4	1.00	2.32	1.16	2.93	6.12	6.43	5.02	5.49	3.19	2.94
PLA2G2A	4	1.00	0.68	1.09	0.70	21.42	1.73	4.59	151.14	4.10	1.13
PLAT	1,2	1.00	3.56	3.20	3.97	13.43	23.95	25.60	28.49	10.42	5.29
PMP22	1	1.00	2.38	2.62	3.41	4.31	3.96	4.24	6.86	2.93	2.17
PPARD	4	1.00	0.70	0.24	0.63	0.49	0.35	1.11	0.78	0.48	1.11

Continued on next page

Table 1. Continued.

Gene	Associate to transcription factors	Recovery time (h) after partial hepatectomy									
		0	2	6	12	24	30	36	72	120	168
<i>PPP2R1B</i>	5	1.00	6.23	5.07	9.81	5.08	10.37	11.63	5.91	4.36	4.87
<i>PRL</i>	1,4	1.00	0.99	4.50	0.82	2.46	2.40	0.98	1.05	0.80	2.48
<i>PTAFR</i>	4	1.00	1.14	0.95	2.46	3.64	7.29	1.15	3.56	3.40	2.66
<i>PTEN</i>	4,5	1.00	0.97	0.70	0.93	0.77	1.20	0.83	0.94	1.09	1.20
BE103748	4,5	1.00	1.43	0.57	2.59	5.95	3.58	4.86	8.84	3.07	2.80
<i>PTP4A1</i>	5	1.00	3.33	2.11	1.53	1.47	1.61	1.28	0.94	1.29	1.09
<i>PTPN1</i>	4,5	1.00	3.37	2.46	1.89	1.29	1.39	1.23	1.52	1.73	1.53
<i>RARB</i>	1,5	1.00	1.90	0.27	0.92	0.54	0.48	0.52	0.90	1.27	1.13
<i>SI00A10</i>	4	1.00	2.11	2.08	6.19	3.14	9.83	5.40	7.65	3.60	2.87
<i>SI00A4</i>	4	1.00	1.13	3.98	3.49	13.84	12.12	17.77	24.62	6.43	1.30
<i>SELE</i>	2,4	1.00	1.69	3.31	5.46	0.80	0.77	3.02	3.49	2.98	2.63
<i>SERPINE2</i>	4,5	1.00	2.97	5.67	9.72	14.35	4.17	7.30	25.39	7.65	6.58
<i>SPP1</i>	2,4	1.00	5.17	3.25	2.84	3.16	22.11	2.97	10.32	1.56	4.49
<i>SRM</i>	1,5	1.00	1.61	3.32	3.17	1.63	1.39	1.05	0.95	0.98	0.97
<i>ST8SLA1</i>	4	1.00	1.13	0.15	0.93	1.02	0.82	0.65	0.32	0.27	0.23
<i>STAT3</i>	1	1.00	3.90	4.01	2.18	1.39	1.17	1.62	1.84	2.00	1.50
<i>TERT</i>	4,5	1.00	0.96	0.44	0.63	1.64	1.25	1.84	2.80	1.71	3.35
<i>TGFB1</i>	1,2,4,5	1.00	1.19	1.14	1.44	1.88	1.60	1.74	7.05	5.16	2.01
<i>TGFB2</i>	1,5	1.00	1.83	2.25	3.29	2.55	4.31	4.91	5.91	3.26	2.26
<i>THPO</i>	1	1.00	1.44	1.75	1.62	1.40	0.98	1.19	1.74	1.34	1.37
BF405940	1	1.00	1.68	5.49	5.40	2.56	2.35	1.64	5.47	1.44	1.21
<i>TIMP1</i>	1,2,4	1.00	1.88	4.32	4.90	14.94	6.13	8.45	33.89	2.66	1.33
<i>TNC</i>	2,4	1.00	1.77	1.32	1.29	3.23	7.52	1.56	11.08	1.47	5.75
<i>TNF</i>	1,2,4	1.00	1.71	4.98	2.26	1.96	2.80	3.65	3.40	2.03	1.39
<i>TSPAN2</i>	3	1.00	1.19	0.91	1.87	1.18	1.19	1.31	3.13	1.24	1.21
<i>TYMS</i>	5	1.00	0.97	0.85	1.41	5.10	6.92	4.63	1.57	1.36	1.06
<i>UPK1B</i>	4	1.00	1.87	3.22	2.28	5.05	3.26	3.77	17.82	3.39	3.78
<i>WISP1</i>	1,3	1.00	2.31	5.62	2.25	6.47	2.81	1.51	14.13	6.12	8.02
<i>WT1</i>	4,5	1.00	2.55	3.19	3.63	2.04	2.48	1.65	3.60	1.96	1.78

*Values in red represent the expression levels of up-regulated genes, those in green are down-regulated genes, and those in black were insignificantly changed. The symbols in yellow indicate unknown genes homologous to the above known genes. Numbers 1-5 show the transcription factors CREB, C-JUN/C-FOS, NFAT, NF- κ B, and C-MYC, respectively.

Relationships between the signal transduction activity of 3 branches of the PLC signaling pathway and HC growth

The relationships between the signal transduction activity of the PLC signaling pathway and cell growth were analyzed by using a mathematical model (E_t) to analyze the synergy among PLC signaling pathway-related genes in HCs. We found that the signal transduction activity of the PLC signaling pathway was increased during LR and peaked at 72 h. Similarly, E_t values of genes related to the branch of GFR/PLC were dramatically higher than those in the normal control and SO groups during whole LR and peaked at 72 h, while the E_t values of GPCR/PLC- and integrin/PLC-related genes were higher than those in normal control and SO groups at 6-168 h (progression and termination phase of LR), but not at 2 h. The E_t values of HC growth-related genes were greater than those in the normal control and SO groups and peaked at 72 h during whole LR after PH. Furthermore, the E_t values of the double-messenger system (including IP_3 - Ca^{2+} and DAG-PKC)-regulated HC growth-related genes were also higher than those in the normal control and SO groups, and were both significantly higher at 72 h than at other time points (Figure 4).

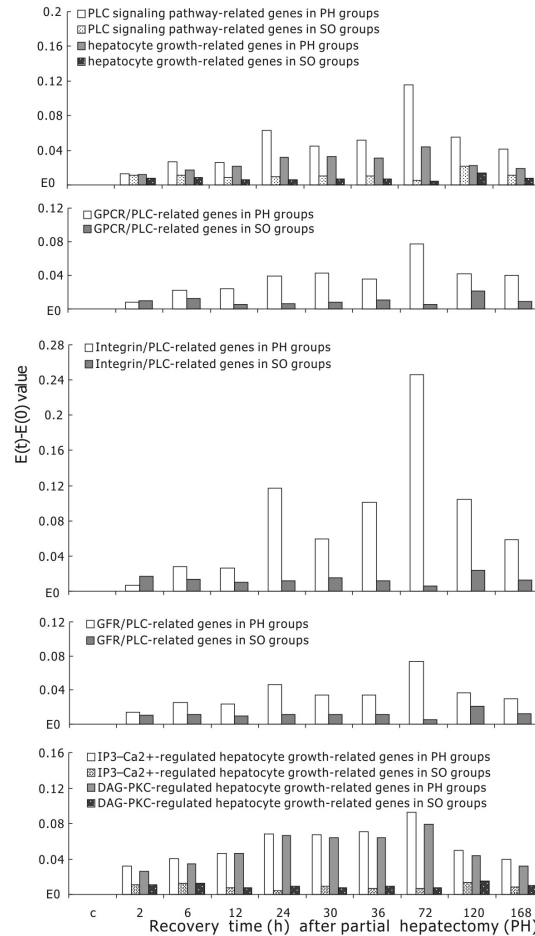

Figure 4. Cell growth regulated by PLC signaling pathway branches of hepatocytes in liver regeneration.

Analysis of correlation between signal transduction activity of targets regulated by TF and HC growth

In the present study, based on the information from TRED and Lymph TF DB, a total of 1273 targets were identified to be regulated by TFs related to the PLC signaling pathway, including *NFAT*, *CREB*, *C-JUN*, *C-FOS*, *NF- κ B*, and *C-MYC* contained in the Rat Genome 230 2.0 Microarray, 166 of which were related to cell growth.

To analyze the correlation between the PLC signaling pathway and HC growth in rat LR, a spectrum function $E(t)$ was used to analyze the synergetic effect of total target genes and cell growth-related target genes regulated by TFs in this pathway. The results demonstrated that the $E(t)$ values were both significantly higher than control values during whole LR after PH, reaching a peak at 72 h. The results indicated that the synergetic effects of total target genes and targets related to cell growth in the PLC signaling pathway showed a similar pattern in general during LR after PH (Figure 5).

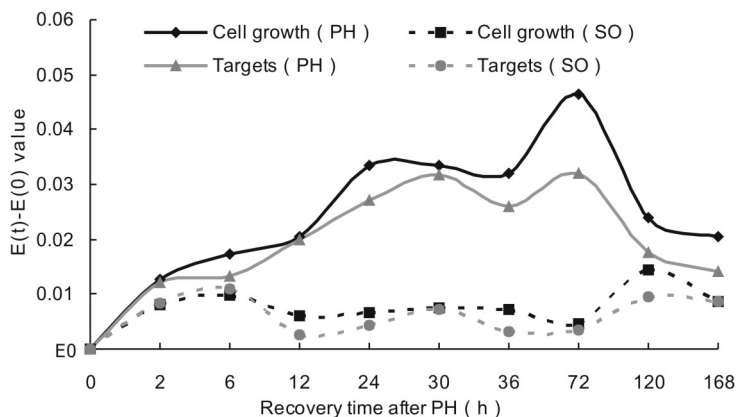

Figure 5. Correlation between PLC pathway and HC growth in regenerating HCs after PH.

DISCUSSION

The liver is a crucial substantive organ in the human body and participates in a variety of important and complex physiological functions, including bile secretion, metabolism, blood coagulation, detoxification, and immunity. Liver dysfunction caused by liver damage, physical factors, and chemical factors directly endangers health and safety. Currently, the treatment of liver diseases remains limited. There are various factors limiting the physiological role of the liver, including HC growth. In addition, the mechanism of liver regeneration is not well understood, making it difficult to effectively promote HC growth and LR. Previous studies have shown that the liver has high regenerative ability (Fausto et al., 1995). LR is a process involving numerous factors stimulated in HCs to facilitate growth. The PLC signaling pathway participates in various physiological activities, including cell growth (Moolenaar et al., 1984; Cockcroft and Thomas, 1992; Cerbon et al., 2009). Therefore, in our study, the expression profiles of genes in regenerating HCs after PH were detected using the Rat Genome 230 2.0 Microarray, and their synergetic effects were assessed using a mathematical model (E_i). The E_i value of target genes related to cell growth in the PLC pathway was enhanced during whole rat LR, suggesting the potential positive effect of PLC on HC growth during rat LR.

Previous studies demonstrated that PLC is activated through a combination of the activated GPCR and $G\alpha_q$, integrin and extracellular matrix, and growth factor and its receptor in PLC signaling pathways (Kawakami and Xiao, 2013). In this study, the expression of *PLCD4* (encoding a member of the PLC δ family) was up-regulated in rat HCs. These results are consistent with those of Crljen et al. (2004), who reported that PLC activity was increased after rat PH. It is generally acknowledged that activation of the PLC cascade stimulates the double-messenger system. The IP_3 - Ca^{2+} system plays an important role in regulating cell volume, secretion, and other activities. PKC can regulate glycogen metabolism, inhibit glycogen synthesis, phosphorylate some intracellular TFs, and induce mRNA synthesis. This plays a significant role in cell division, proliferation, growth, and metabolism.

As previously reported, GPCRs can regulate the growth of various cell types. Some GPCR agonists have also been found to induce expression in the HCs of some early response genes that play a role in transcription programs necessary for cell growth, such as C-FOS and

C-MYC (Nilssen et al., 2004). Silverman et al. (1989) also reported that the expression of *C-MYC* increased at 3 h after PH. Moreover, You et al. (2013) reported that *ADORA2A* was increased in the liver after acute injury. Recent studies have shown that RHOA and RHOB (members of Rho-GTPase family) stimulated PLC activation (Bunney et al., 2009). In our study, the expression of GPCR/PLC branch-related genes detected by high-throughput analysis revealed that some members of the GPCR family were up-regulated during rat LR, such as *ADORA2A*, which was up-regulated at 72 h, *DRD1A* at 12, 36, and 72 h, *HTR4* at 72 h, and *BF401317* (homologous to *HTR4*) at 30-120 h. In addition, the expression changes in *MYC* (encoding c-MYC) were up-regulated at 2 and 24 h and *RHOB* (encoding RHOB) at 2-6 h. Analysis of gene synergy showed that the signal transduction activity of the GPCR/PLC branch was strengthened at 6-168 h during rat LR.

Zhang et al. (2004) found that the expression of laminin protein was increased at 12 h after PH in rat LR. In our study, the expression of integrin/PLC branch-related genes showed that the genes coding laminin were up-regulated during LR, including *LAMA1*, which was up-regulated at 2-12, 30, 72, and 120 h, *LAMA5* at 2 and 12-168 h, *LAMB1* at 12-72 and 168 h, *LAMC1* at 2 h, and *LAMC2* at 72 h. In addition, the expression changes of collagen and fibrillar increased in LR. The family members of integrin were also up-regulated during LR, including *ITGA9*, which was up-regulated at 12-30, 72, and 120 h, *ITGAI1* at 2, 24, 36, and 120 h, *ITGAM* at 30 h, both *ITGB6* and *ITGB7* at 72 h, and *AI717063* (homologous to *ITGB2*) at 6 and 12 h. The gene synergy results of the integrin/PLC branch demonstrated that signal transduction activity was also enhanced at 6-168 h during rat LR.

Hepatocyte growth factor (HGF) is a potent mitogen for mature HCs and acts as a vital factor in regenerating the rat liver. Moreover, HGF mRNA and protein were rapidly and markedly increased in the liver and plasma of rats with various types of liver injuries (Matsumoto and Nakamura, 1992; Nakamura, 1994). The present data suggested that the *HGF* gene was up-regulated at 6, 24-30, and 72 h in the GFR/PLC branch during rat LR. Furthermore, changes in the expression of many genes encoding GF and GFR were up-regulated in LR. The E_i value of this branch showed that the signal transduction activity of the GFR/PLC branch was increased during whole rat LR. Cell growth occurs through the activity of a variety of signaling pathways; in our study, the E_i values of the 3 branch-related genes were analyzed. The results showed that the signal transduction action of the PLC signaling pathway was increased in whole rat LR.

The expression of TF-related genes in the PLC pathway was analyzed. The *CREB1* gene (encoding CREB) was up-regulated at 6 and 36-72 h in the IP_3 - Ca^{2+} system during rat LR. In addition, the DAG-PKC system induced *MYC* (encoding transcription factor C-MYC) up-regulation at 2 and 24 h during rat LR. Three genes were activated in these 2 pathways; *JUN* was up-regulated at 2 and 24 h, *FOS* at 2, 12-24, 72, and 168 h, and *BF419700* (homologous to NF- κ B family member *RELA*) at 24, 36, and 168 h. The E_i value was used to analyze HC growth. HC growth was enhanced during rat LR. These results indicate a positive correlation between signal transduction and HC growth activities, indicating that the PLC signaling pathway promoted HC growth through the GFR/PLC branch during the initiation phase, and the above 3 branches in the progression and terminal phase of rat LR.

In conclusion, we performed a large-scale analysis of gene expression profiles and obtained detailed data for rat LR at the cellular level. These data indicate the potential positive relevance of PLC and HC growth in the GPCR/PLC, integrin/PLC, and GFR/PLC branches at the transcriptional level in rat LR after PH. These results are mainly drawn from gene expression changes detected using the Rat Genome 230 2.0 Microarray. Microarray data can only

identify changes in gene transcription, but cannot reflect the protein synthesis process, and are even less able to accurately reflect PLC signaling pathway activities and their final biological effects. Future studies should involve gene knockout, gene addition, RNA interference, proteomic analysis, and protein interaction analysis to clarify these mechanisms.

ACKNOWLEDGMENTS

Research supported by the National Basic Research “973” Pre-Research Program of China (#2012CB722304), the Natural Science Foundation of Henan Province (#122300410355, #122300410339 and #122300413207), and the Major Scientific and Technological Projects of Henan (#111100910600).

[Supplementary material](#)

REFERENCES

- Amon RR, DuBois DC, Pearson KE, Stephan DA, et al. (2003). Gene arrays and temporal patterns of drug response: corticosteroid effects on rat liver. *Funct. Integr. Genomics* 3: 171-179.
- Antonov AV, Schmidt EE, Dietmann S, Krestyaninova M, et al. (2010). R spider: a network-based analysis of gene lists by combining signaling and metabolic pathways from Reactome and KEGG databases. *Nucleic Acids Res.* 38: W78-W83.
- Brenner DA (1998). Signal transduction during liver regeneration. *J. Gastroenterol. Hepatol.* 13: S93-S95.
- Bunney TD, Baxendale RW and Katan M (2009). Regulatory links between PLC enzymes and Ras superfamily GTPases: signalling via PLCepsilon. *Adv. Enzyme Regul.* 49: 54-58.
- Caetano MS, Vieira-de-Abreu A, Teixeira LK, Werneck MB, et al. (2002). NFATC2 transcription factor regulates cell cycle progression during lymphocyte activation: evidence of its involvement in the control of cyclin gene expression. *FASEB J.* 16: 1940-1942.
- Carbon J, Olguin T, Alvarez-Grave PR and López-Sánchez RC (2009). *Entamoeba invadens*: sphingolipids metabolic regulation is the main component of a PKC signaling pathway in controlling cell growth and proliferation. *Exp. Parasitol.* 122: 106-111.
- Childress PJ, Fletcher RL and Perumal NB (2007). LymphTF-DB: a database of transcription factors involved in lymphocyte development. *Genes Immun.* 8: 360-365.
- Cockcroft S and Thomas GM (1992). Inositol-lipid-specific phospholipase C isoenzymes and their differential regulation by receptors. *Biochem. J.* 288: 1-14.
- Crljen V, Visnjić D and Banfić H (2004). Presence of different phospholipase C isoforms in the nucleus and their activation during compensatory liver growth. *FEBS Lett.* 571: 35-42.
- de Menezes RX, Boer JM and van Houwelingen HC (2004). Microarray data analysis: a hierarchical T-test to handle heteroscedasticity. *Appl. Bioinformatics* 3: 229-235.
- Fausto N (2004). Liver regeneration and repair: hepatocytes, progenitor cells, and stem cells. *Hepatology* 39: 1477-1487.
- Fausto N, Laird AD and Webber EM (1995). Liver regeneration. 2. Role of growth factors and cytokines in hepatic regeneration. *FASEB J.* 9: 1527-1536.
- Fukami K, Inanobe S, Kanemaru K and Nakamura Y (2010). Phospholipase C is a key enzyme regulating intracellular calcium and modulating the phosphoinositide balance. *Prog. Lipid Res.* 49: 429-437.
- Graef IA, Wang F, Charron F, Chen L, et al. (2003). Neurotrophins and netrins require calcineurin/NFAT signaling to stimulate outgrowth of embryonic axons. *Cell* 113: 657-670.
- Higgins GM and Anderson RM (1931). Experimental pathology of the liver: Restoration of the liver of the white rat following partial surgical removal. *Arch. Pathol.* 12: 186-202.
- Jiang C, Xuan Z, Zhao F and Zhang MQ (2007). TRED: a transcriptional regulatory element database, new entries and other development. *Nucleic Acids Res.* 35: D137-D140.
- Kawakami T and Xiao W (2013). Phospholipase C-β in immune cells. *Adv. Biol. Regul.* 53: 249-257.
- Kountouras J, Boura P and Lygidakis NJ (2001). Liver regeneration after hepatectomy. *Hepatogastroenterology* 48: 556-562.
- Mantamadiotis T, Papalexis N and Dworkin S (2012). CREB signalling in neural stem/progenitor cells: recent developments and the implications for brain tumour biology. *Bioessays* 34: 293-300.

- Matsumoto K and Nakamura T (1992). Hepatocyte growth factor: molecular structure, roles in liver regeneration, and other biological functions. *Crit. Rev. Oncog.* 3: 27-54.
- Moolenaar WH, Tertoolen LGJ and de Laat SW (1984). Growth factors immediately raise cytoplasmic free Ca²⁺ in human fibroblasts. *J. Biol. Chem.* 259: 8066-8069.
- Moore-Carrasco R, Busquets S, Figueras M, Palanki M, et al. (2009). Both AP-1 and NF-kappaB seem to be involved in tumour growth in an experimental rat hepatoma. *Anticancer Res.* 29: 1315-1317.
- Mulrane L, Rexhepaj E, Smart V, Callanan JJ, et al. (2008). Creation of a digital slide and tissue microarray resource from a multi-institutional predictive toxicology study in the rat: an initial report from the PredTox group. *Exp. Toxicol. Pathol.* 60: 235-245.
- Nakamura T (1994). Hepatocyte growth factor as mitogen, motogen and morphogen, and its roles in organ regeneration. *Princess Takamatsu Symp.* 24: 195-213.
- Nikitin A, Egorov S, Daraselia N and Mazo I (2003). Pathway studio - the analysis and navigation of molecular networks. *Bioinformatics* 19: 2155-2157.
- Nilssen LS, Odegard J, Thoresen GH, Molven A, et al. (2004). G protein-coupled receptor agonist-stimulated expression of ATF3/LRF-1 and c-myc and comitogenic effects in hepatocytes do not require EGF receptor transactivation. *J. Cell Physiol.* 201: 349-358.
- Salomonis N, Hanspers K, Zambon AC, Vranizan K, et al. (2007). GenMAPP 2: new features and resources for pathway analysis. *BMC. Bioinformatics* 8: 217.
- Sankian M, Varasteh A, Pazouki N and Mahmoudi M (2005). Sequence homology: a poor predictive value for profilins cross-reactivity. *Clin. Mol. Allergy* 3: 13.
- Sell S (2003). The hepatocyte: heterogeneity and plasticity of liver cells. *Int. J. Biochem. Cell Biol.* 35: 267-271.
- Silverman JA, Zurlo J, Watson MA and Yager JD (1989). Expression of c-raf-1 and A-raf-1 during regeneration of rat liver following surgical partial hepatectomy. *Mol. Carcinog.* 2: 63-67.
- Steer CJ (1995). Liver regeneration. *FASEB J.* 9: 1396-1400.
- Sun Y, Deng X, Li W, Yan Y, et al. (2007). Liver proteome analysis of adaptive response in rat immediately after partial hepatectomy. *Proteomics* 7: 4398-4407.
- Taub R (2004). Liver regeneration: from myth to mechanism. *Nat. Rev. Mol. Cell Biol.* 5: 836-847.
- Vardhanabhuti S, Blakemore SJ, Clark SM, Ghosh S, et al. (2006). A comparison of statistical tests for detecting differential expression using Affymetrix oligonucleotide microarrays. *OMICS* 10: 555-566.
- Wang GP and Xu CS (2010). Reference gene selection for real-time RT-PCR in eight kinds of rat regenerating hepatic cells. *Mol. Biotechnol.* 46: 49-57.
- Xu C, Chen X, Chang C, Wang G, et al. (2010). Transcriptome analysis of hepatocytes after partial hepatectomy in rats. *Dev. Genes Evol.* 220: 263-274.
- Xu C, Yang Y, Yang J, Chen X, et al. (2012). Analysis of the role of the integrin signaling pathway in hepatocytes during rat liver regeneration. *Cell. Mol. Biol. Lett.* 17: 274-288.
- Xu CS, Zhang SB, Chen XG and Rahman S (2007). Correlation analysis of liver tumor-associated genes with liver regeneration. *World J. Gastroenterol.* 13: 3323-3332.
- You Q, Holt M, Yin H, Li G, et al. (2013). Role of hepatic resident and infiltrating macrophages in liver repair after acute injury. *Biochem. Pharmacol.* 86: 836-843.
- Zhang SL, Zhang GJ, Jia YF, Song XL, et al. (2004). The changes of expression of integrin $\alpha 1$, laminin and IL-1 α and their roles during rat liver regeneration. *Acta Anat. Sin.* 35: 624-631.